

Dyestuff Dissolving and Dosing System DDS



The Dyestuff Dissolving and Dosing System DDS is used to supply textile machines and other machines with dyestuff solutions. Depending on the used controllers on the machines, the dyestuff is supplied in fully automatic mode. The controller of the machine requests the required dyestuff via the host computer, the operator in the dyestuff room weighs it and pours the dyestuff into the DDS and confirms the operation. The DDS dissolves the dyes and sends them to the machine. Finally the DDS confirms that the dissolved dyestuff has been sent to the tank as requested.

A standard system is equipped with 3 main modules:

- Controller
- Dyestuff dissolving system including the transfer pump
- Distribution module

Each module can be placed independently somewhere inside the factory so that also complicated layouts can be realized. For example, one dyestuff dissolving system can supply two dyehouses by using two distribution modules.

Diagram

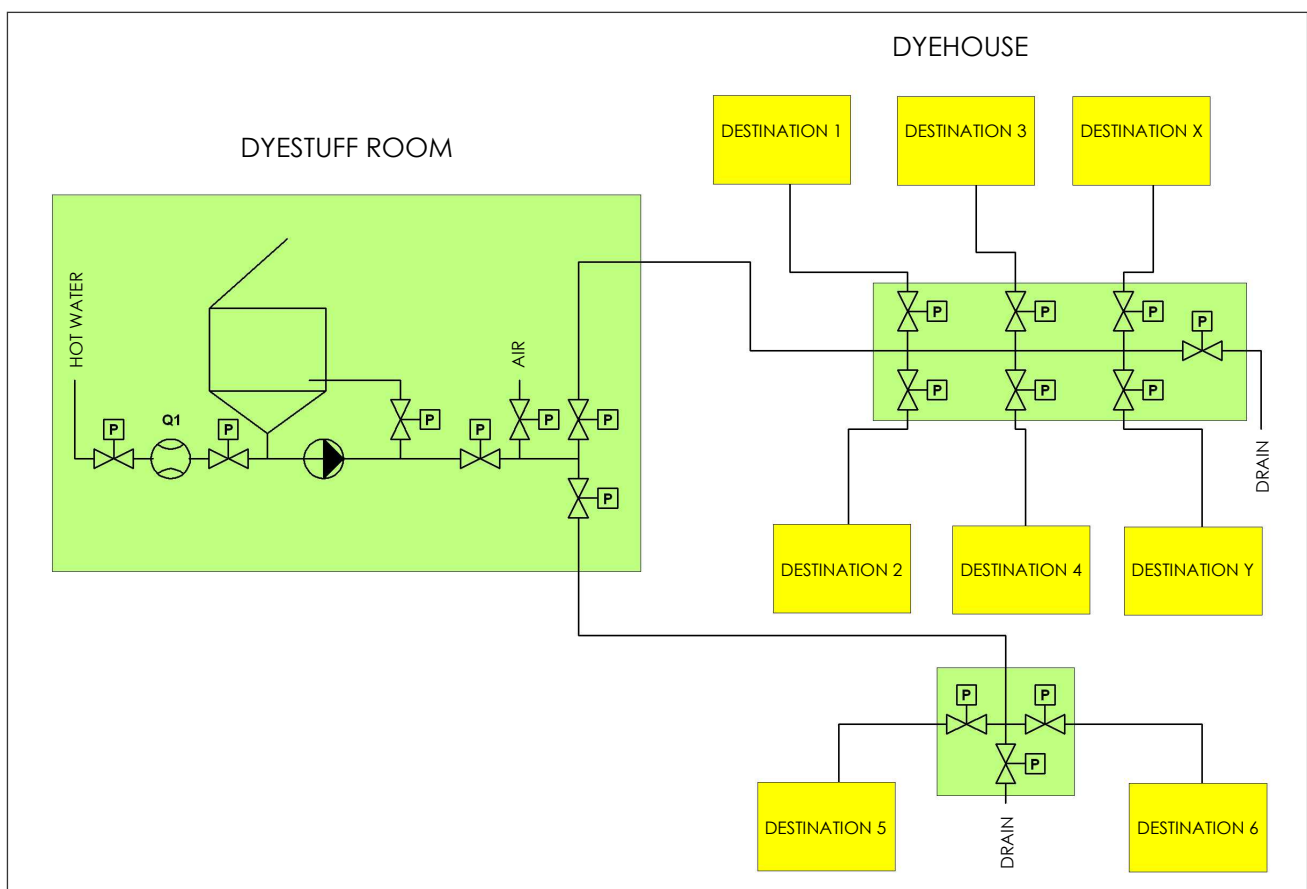

SYS 124.0 e

The heart of the Dyestuff Dissolving and Dosing System DDS is the polished mixing vessel. It is equipped with a mixing and transfer pump, hot water inlet and direct steam heating to dissolve the dyes according to the specified dissolving program. Up to 300 liters of dyestuff solution can be produced, i.e. depending on the dyestuff, up to 40 – 50 kg of dyestuff can be dissolved and transferred to the dyeing machines. The whole process of mixing and transferring the dyestuff takes 10 to 20 minutes, depending on the dyestuff and the amount of dyestuff.

The whole system is made of stainless steel and allows to mix and transfer 98 % of the available dyestuffs used in the textile industry. All components (valves, flanges and piping) are specially designed for low contamination and fast wash out.

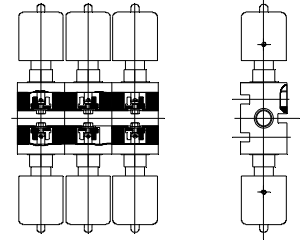

Capacities:

- Dyestuff up to 50 kg
- Vessel 300 liters